

# Module Enclosure SMB-1



## Features

- \* Quick-release screws
- \* Polyurethane gasket provides IP66 protection
- \* Corrosion free, resistant to most alkaline and acid
- \* Temperature resistance to +70°C, Impact resistant, and Non-flammable
- \* 32 knock-outs

## Description

Model SMB-1 is from a range of IP66 rated, grey (RAL7035) enclosures, designed for use with the Hochiki range of Modules. The SMB-1 features a selection of metric knock-outs and is supplied with a transparent black lid as standard. Used in conjunction with the SMB-ADAPTOR, an adaptor plate (sold separately), this enclosure can house any of the PCB assemblies from the

Hochiki Smart-Fix Module range or the CHQ-SIM, CHQ-POM or CHQ-SOM “mini” modules (see over for further details).

Specification		
Ordering codes	SMB-1 Base c/w transparent lid	SMB-1(LID) Opaque lid
Ingress Protection rating	IP66	N/A
Colour	Box - Grey (RAL7035) Lid - Transparent black	Grey (RAL7035)
Material	Box - Polystyrene Lid - Polycarbonate	Polystyrene
Weight (g)	655	245
Dimensions (mm)	L254 x W180 x H90	L254 x W180 x H18
Knock-out configuration	Long sides	1 x M32/40 2 x M25/32 8 x M20
	Short sides	1 x M32/40 4 x M20
Suitable protection against	Weak alkali, strong alkali, alcohol, petrol, benzene, mineral oil, diesel, ammonia, vegetable oil, animal oil	

**SMB-ADAPTOR – Typical Configurations**

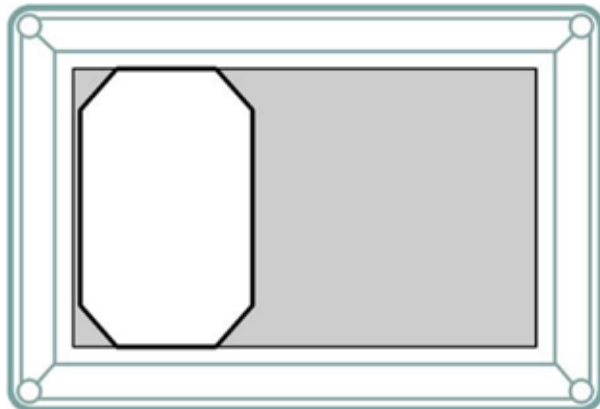

SMB-ADAPTOR with 1 CHQ-ADAPTOR (+ PCB)  
(fitted portrait)

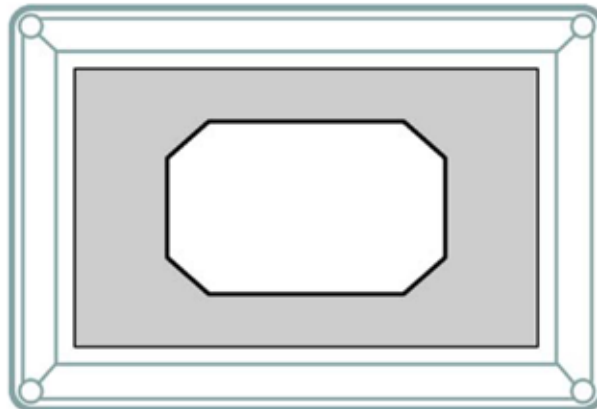

SMB-ADAPTOR with 1 CHQ-ADAPTOR (+ PCB)  
(fitted landscape)

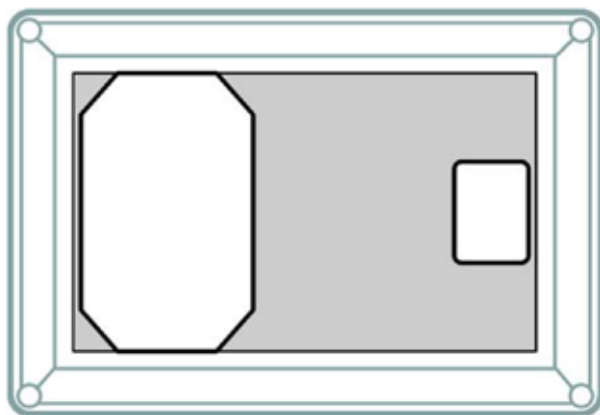

SMB-ADAPTOR with 1 CHQ-ADAPTOR (+ PCB) and 1 'mini' CHQ (for example, CHQ-POM)

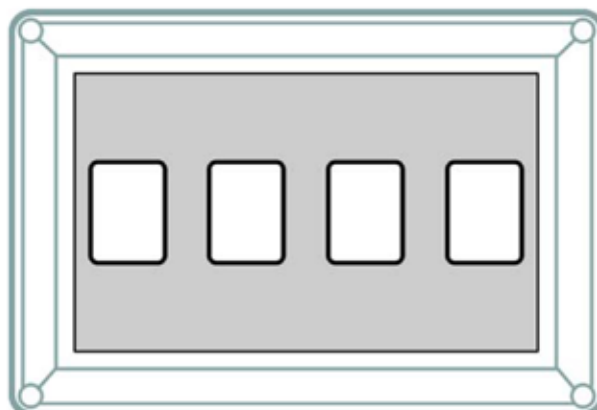

SMB-ADAPTOR with 4 'mini' CHQ (for example, CHQ-POM)

**FASTENER INFORMATION:**

For Mounting plate (always required)  
For CHQ Module PCB  
washers  
For 'mini' CHQ

4 x M3 CTSK Self Tapper  
2 x M4 Pan Head Screws + 2 split  
washers  
2 x M3 CTSK Machine Screws